

RHON HERNDON

RHON HERNDON
PUBLIC WORKS DIRECTOR



DEPARTMENT OF
PUBLIC WORKS

CLASS 1 LOT GRADING

SCALE: NONE
REVISED: JANUARY 1, 2010
DRAWN BY: J MCKINNEY
APPROVED BY: RHON HERNDON

GR-1

NOTES:

1. LOTS CAN BE GRADED AS A PAD WITH A MINIMUM 1% GRADE TOWARD THE STREET -OR- LOTS CAN GRADED FLAT WITH DRAINAGE DITCHES EXTENDING THE LENGTH OF THE SIDE LOT LINE WITH A MINIMUM 1% GRADE TOWARD THE STREET.

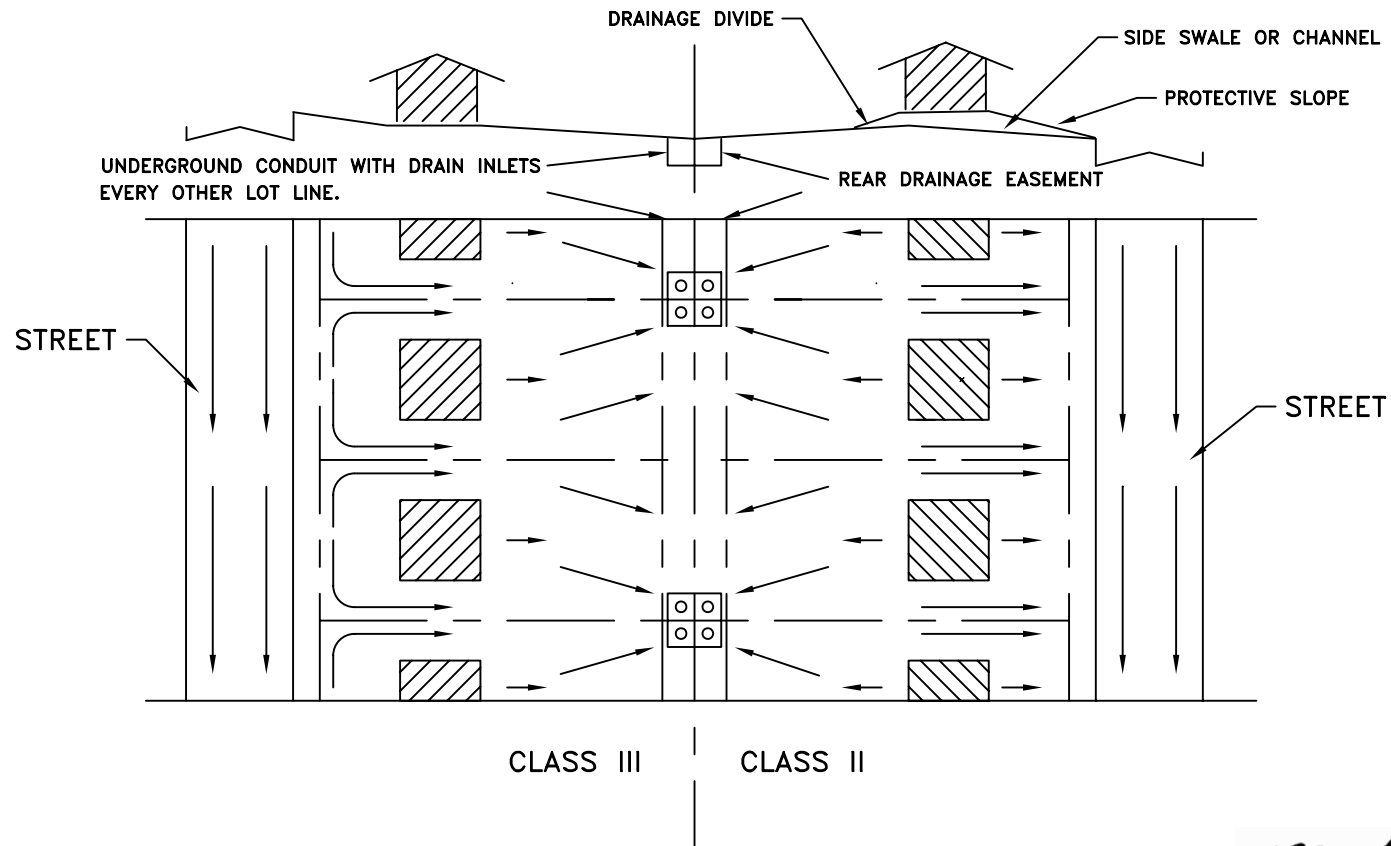

RHON HERNDON

RHON HERNDON
PUBLIC WORKS DIRECTOR



DEPARTMENT OF
PUBLIC WORKS

LOT GRADING
CLASS II AND III

SCALE: NONE
REVISED: JANUARY 1, 2010
DRAWN BY: J MCKINNEY
APPROVED BY: RHON HERNDON

GR-2

NOTES:

1. THOSE LOTS WHICH DO NOT DRAIN TOWARDS EXISTING OR FUTURE LOTS MAY ELIMINATE THE USE OF REAR LOT DRAINS PROVIDED ADDITIONAL EROSION CONTROL MEASURES ARE IMPLEMENTED SUBJECT TO APPROVAL OF THE CITY ENGINEER.
2. EACH LOT TO HAVE IT'S OWN INLET.
3. STORM DRAIN SYSTEM SHALL BE LOCATED IN A PRIVATE DRAINAGE EASEMENT AND MAINTAINED BY PROPERTY OWNER.

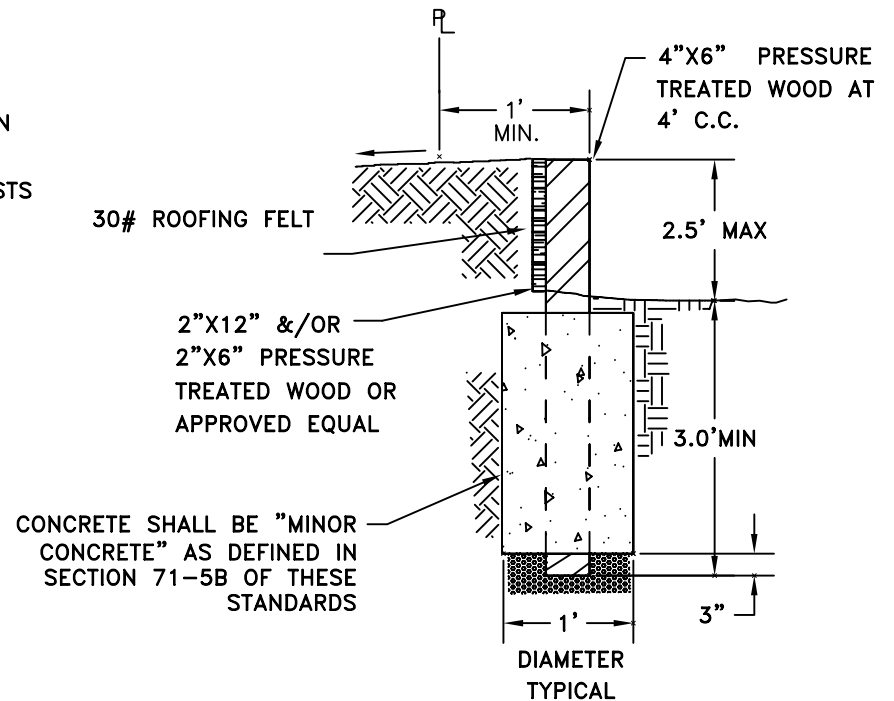
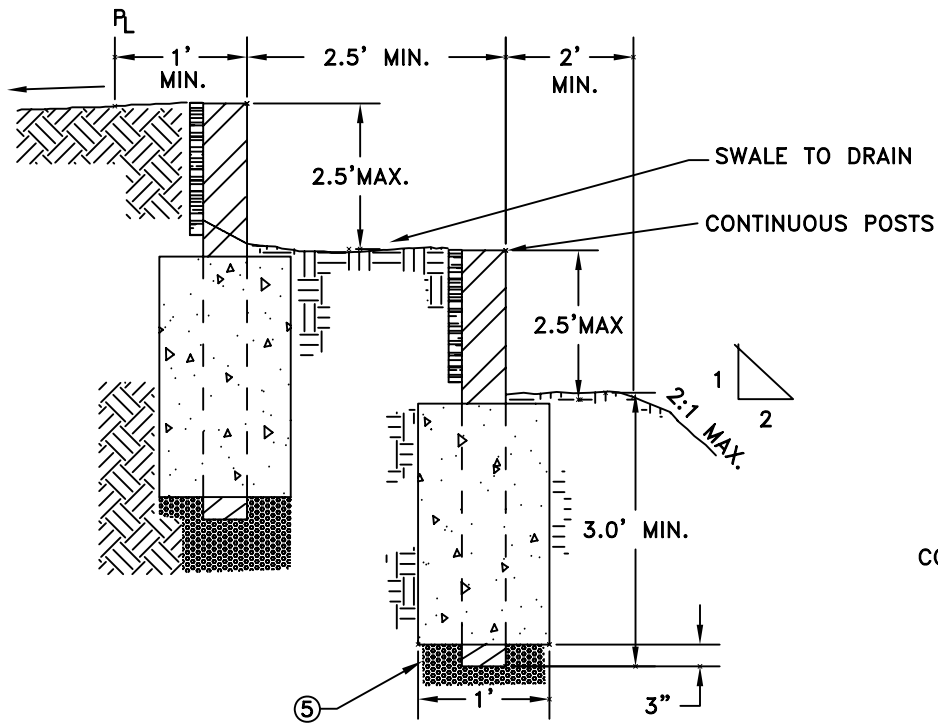

CONCRETE SHALL BE "MINOR CONCRETE" AS DEFINED IN SECTION 71-5B OF THESE STANDARDS

RHON HERNDON

RHON HERNDON
PUBLIC WORKS DIRECTOR

NOTES:

1. MATERIAL FOR WOODEN WALLS SHALL BE PRESSURE TREATED WOOD OR APPROVED EQUAL BY THE CITY ENGINEER PRIOR TO INSTALLATION.
2. ALL METAL HARDWARE TO BE CORROSIVE RESISTANT PER UBC STANDARDS.
3. WOODEN WALLS SHALL NOT BE USED ADJACENT TO STREET RIGHT OF WAYS.
4. 4" X 6" POSTS AT 4' CENTERS SHALL BE USED WHEN FENCES ARE ATTACHED TO RETAINING WALLS; MINIMUM EMBEDMENT FOR POSTS SHALL BE 3.0'. -MEETS U.B.C. STANDARDS
5. DRAIN ROCK SHALL BE PLACED AT BASE OF ALL POST HOLES.

 CITY OF ROSEVILLE CALIFORNIA	DEPARTMENT OF PUBLIC WORKS
<h2 style="margin: 0;">WOOD RETAINING WALL</h2>	
SCALE: NONE REVISED: JANUARY 1, 2013 DRAWN BY: J MCKINNEY APPROVED BY: RHON HERNDON	GR-3

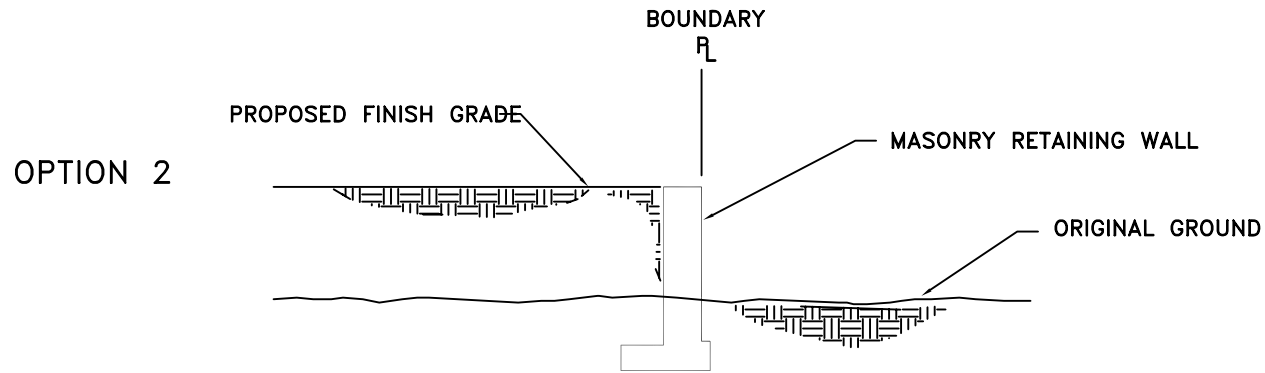
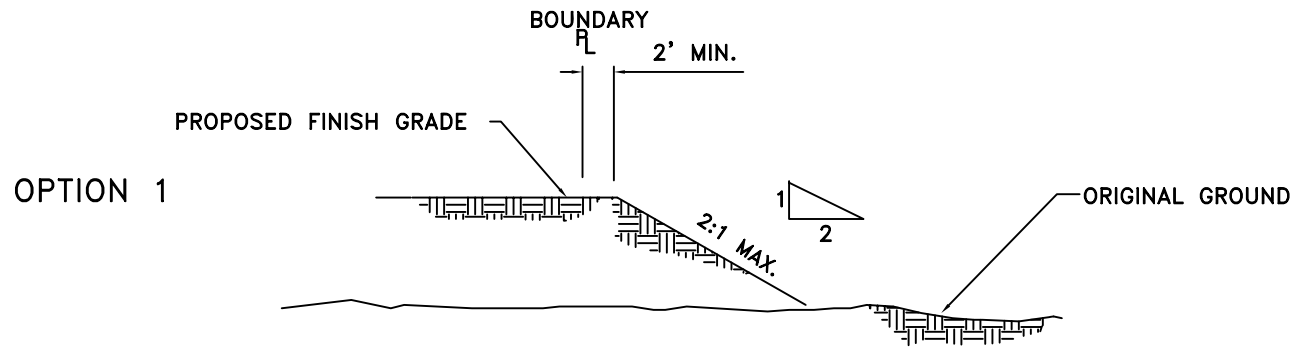

RHON HERNDON
PUBLIC WORKS DIRECTOR

CITY OF
ROSEVILLE
CALIFORNIA

DEPARTMENT OF
PUBLIC WORKS

EXTERIOR PERIMETER
PROPERTY LINE GRADING

NOTE:

1. A NOTARIZED RIGHT OF ENTRY IS REQUIRED FROM ADJACENT PROPERTY OWNER FOR OPTION 1.

SCALE: NONE
REVISED: JANUARY 1, 2010
DRAWN BY: J MCKINNEY
APPROVED BY: RHON HERNDON

GR-4

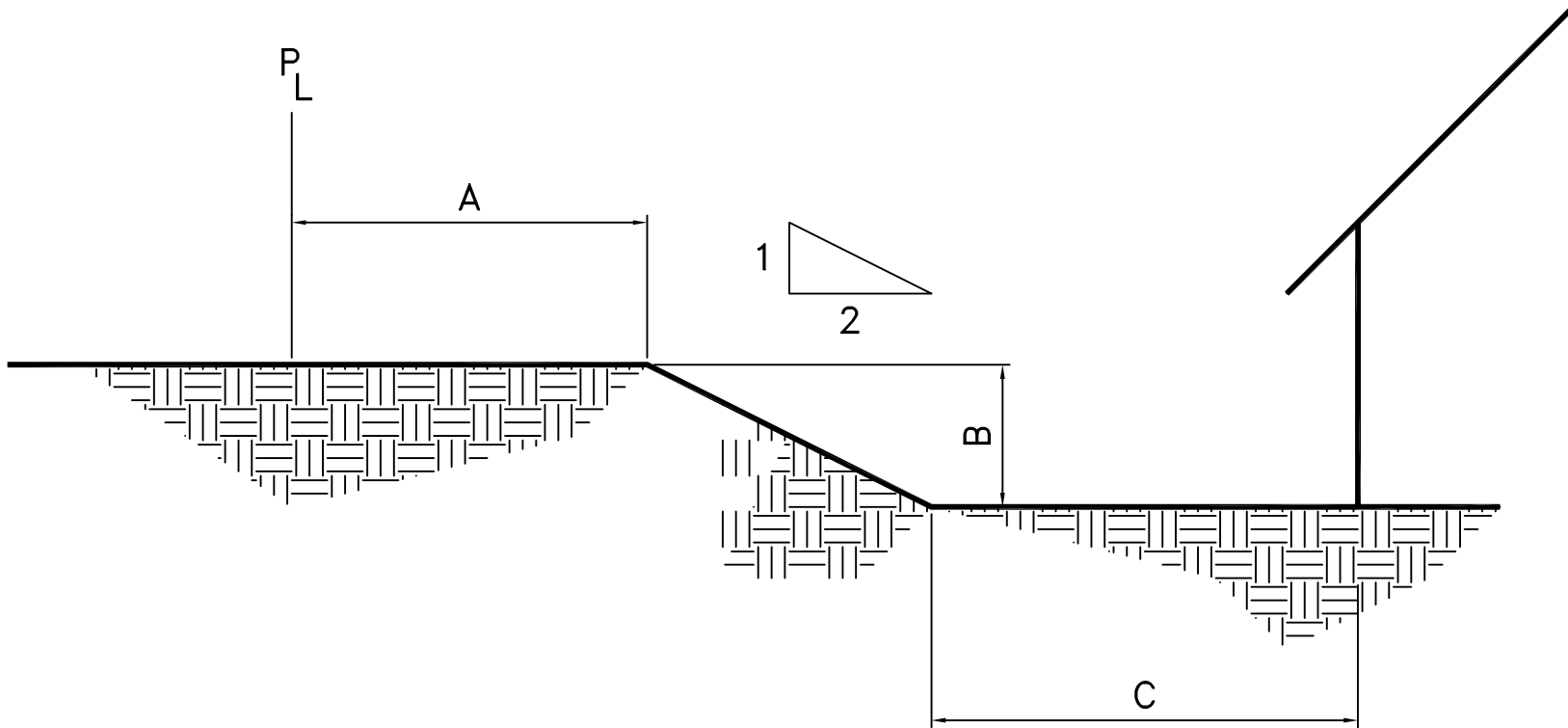

RHON HERNDON

RHON HERNDON
PUBLIC WORKS DIRECTOR



DEPARTMENT OF
PUBLIC WORKS

INTERIOR PROPERTY
LINE GRADING

SCALE: NONE
REVISED: JANUARY 1, 2010
DRAWN BY: J MCKINNEY
APPROVED BY: RHON HERNDON

GR-5

NOTES:

1. WHEN "B" IS LESS THAN OR EQUAL TO 0.5 FEET, "A" = 1.0 FEET.
2. WHEN "B" IS GREATER THAN 0.5 FEET, A RETAINING WALL IS REQUIRED OR A STANDARD LOT SETBACK GUARANTEE PROVIDED. IN SUCH CASE, "A" SHALL EQUAL 2.0 FEET AND "C" SHALL BE A MINIMUM OF 3.0 FEET.